

[LND]

FG60ISODxB10x

RACCOMANDAZIONI PER L'INSTALLAZIONE
 INSTALLATION ADVICE
 RECOMMANDATIONS D'INSTALLATION
 EMPFEHLUNGEN FÜR DIE INSTALLATION
 RECOMENDACIONES PARA LA INSTALACIÓN

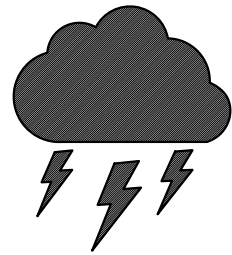

- IT** - Le lampade a LED sono apparecchiature elettroniche e quindi sensibili alle sovratensioni, per questo motivo si consiglia l'installazione nell'impianto di un dispositivo di protezione adeguato (SPD) così da proteggere gli apparecchi dal rischio di danneggiamento.
- EN** - LED lamps are electronic devices and hence sensitive to current surges. For this reason we recommend to install a suitable protective equipment (SPD) to protect the lamp from potential damage.
- FR** - Les lampes LED contiennent de l'électronique et sont donc sensibles aux surtension. Pour cette raison nous recommandons l'utilisation d'un dispositif de protection adéquat (SPD) pour protéger les appareils d'un risque de dommage.
- D** - Die LED-Lampen sind elektronische Geräte und damit empfindlich gegen Überspannung. Aus diesem Grund empfehlen wir den Einbau eines Überspannungsschutzes (SPD) um die Gefahr einer Beschädigung zu vermeiden.
- ES** - Las luminarias a LED son aparatos electrónicos y, por tanto, sensibles a las sobretensiones, por esta razón se recomienda la instalación de un equipo de protección adecuado (STP), a fin de proteger el aparato del riesgo de ser dañado.

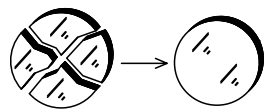

- IT** - In caso di rottura del vetro il prodotto non può essere utilizzato, contattare il fornitore per la sua sostituzione.
- EN** - In case of broken glass the product must not be used, please contact the manufacturer for a replacement.
- FR** - Ne pas utiliser le produit en cas de dommage sur l'écran de protection, contacter le fabricant pour son remplacement.
- D** - Wenn das Glas beschädigt wird, kann das Produkt nicht verwendet werden. Kontaktieren Sie in diesem Fall den Hersteller um das Glas zu ersetzen.
- ES** - No utilizar el producto en caso de rotura del vidrio y contactar el fabricante para la sustitución.

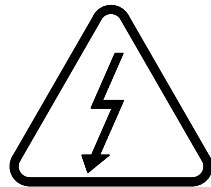

- IT** - Il modulo LED contenuto in questo apparecchio di illuminazione deve essere sostituito esclusivamente dal costruttore, o da personale qualificato equivalente.
- EN** - The LED module contained in this luminaire must only be substituted by the manufacturer or qualified electrician.
- FR** - La source lumineuse contenue dans cet appareil devra uniquement être substituée par le constructeur, ou par installateur qualifié.
- D** - Das LED-Modul, welches in dieser Leuchte enthalten ist, darf nur vom Hersteller oder von Elektrofachpersonal ersetzt werden.
- ES** - El módulo LED contenida en esta luminaria sólo se sustituye exclusivamente del fabricante, o de personal cualificado equivalente.

EN62471:2010-01

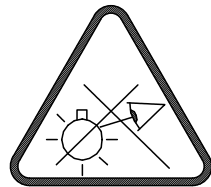

- IT** - L'apparecchio di illuminazione deve essere posizionato in modo che non sia prevista un'osservazione prolungata della sorgente luminosa.
- EN** - The luminaire should be positioned so that prolonged staring into the luminaire is not expected.
- FR** - Le luminaire doit être positionné de telle sorte que personne ne puisse regarder la source de lumière pendant un temps prolongé.
- D** - Die Leuchte sollte so positioniert werden, dass ein längeres Anstarren der Lichtquelle nicht zu erwarten ist.
- ES** - La luminaria debe colocarse de manera que no se prevea una observación prolongada de la fuente de luz.



- IT** - Qualsiasi modifica dell'apparecchio eseguita senza autorizzazione del costruttore fa decadere la garanzia.
- EN** - Any unauthorized modification to the device will automatically void the manufacturer's guarantee.
- FR** - Toute modification non autorisée des produits par le fabricant entrainera un refus de garantie.
- D** - Eine nicht autorisierte Änderung am Gerät führt zum Erlöschen der Herstellergarantie.
- ES** - Cualquier modificación de la luminaria realizada sin la autorización del fabricante anulará la garantía.

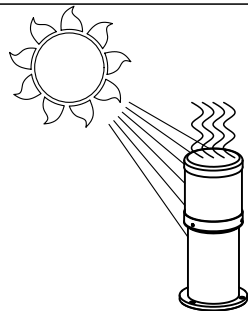

- IT** - Assicurarsi che il prodotto non rimanga acceso durante le ore diurne.
- EN** - Please make sure that the lighting product is correctly switched off during daytime.
- FR** - Priere de s'assurer que le produit d'éclairage soit éteint pendant les heures de la journée.
- D** - Bitte beachten Sie: das Beleuchtungsprodukt muss im Lauf der Tagstunden aus sein.
- ES** - Asegúrese de que el producto no permanezca encendido durante el día.

[LND]

FG60ISODxB10x

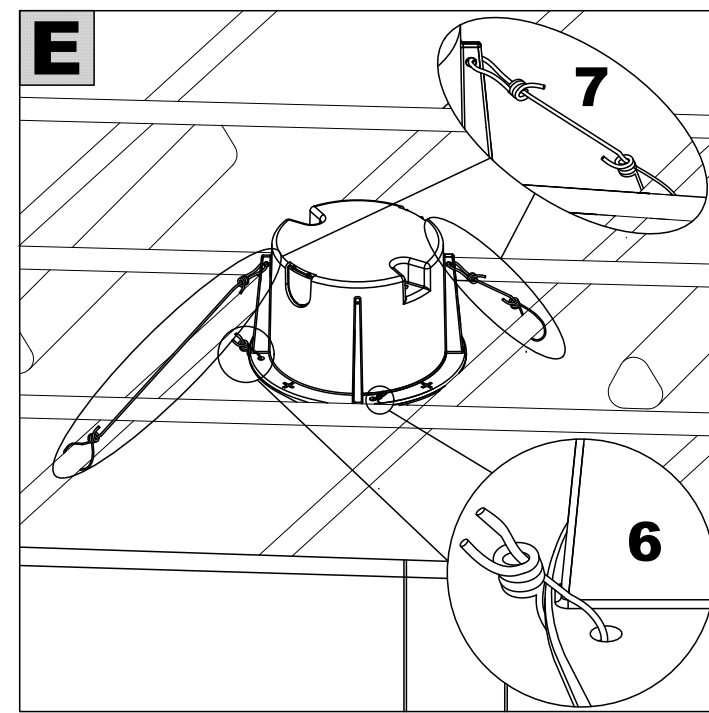
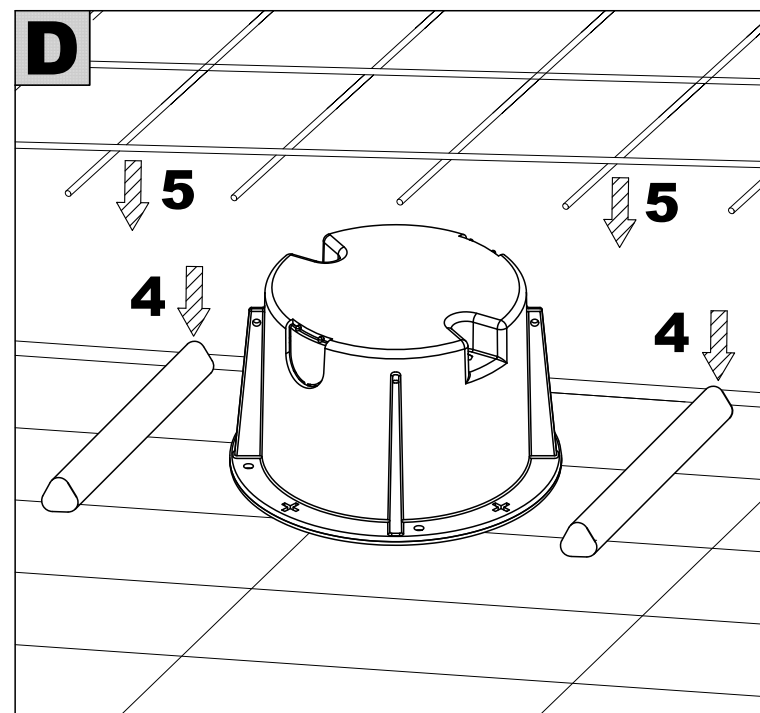
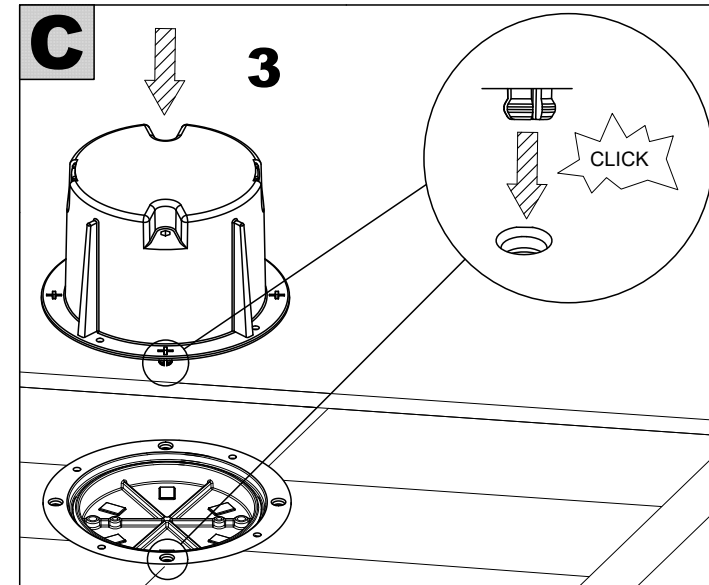
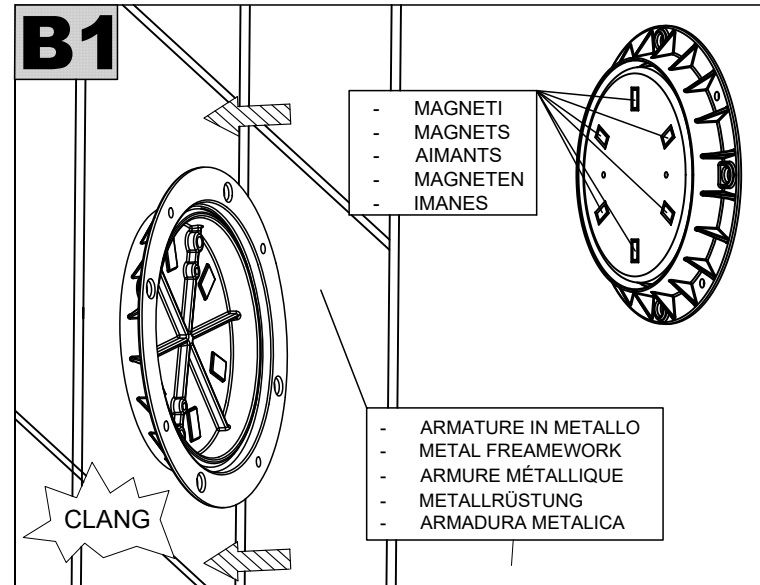
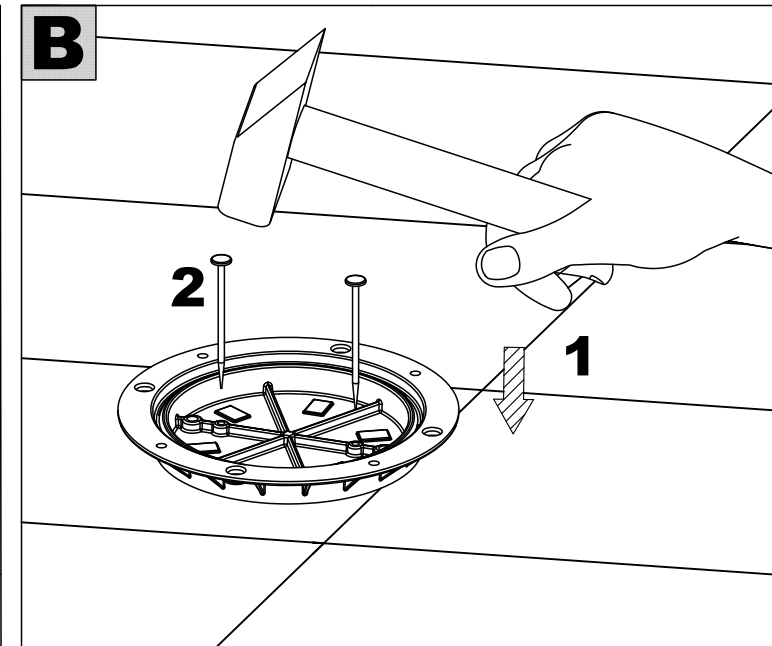
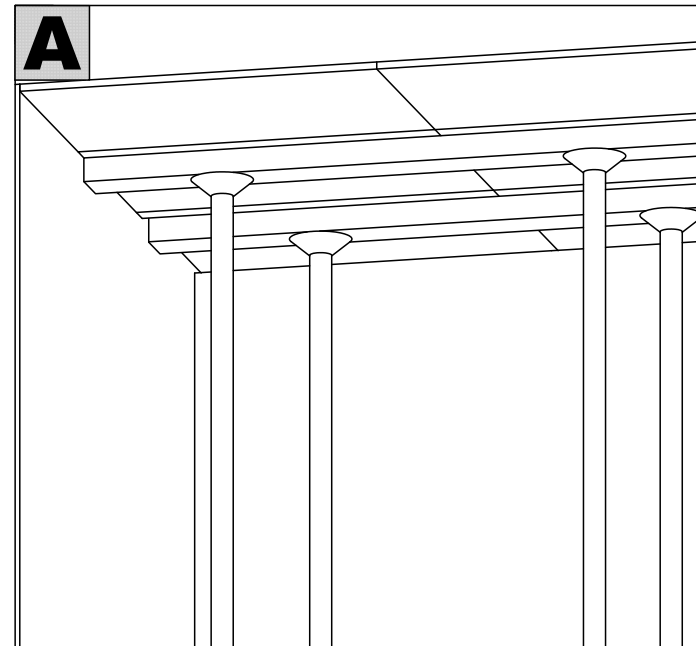
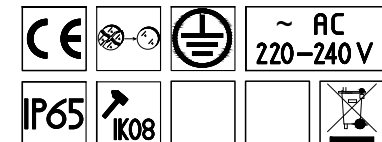

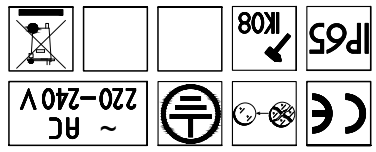

[LNJ] FG60ISODXB10X

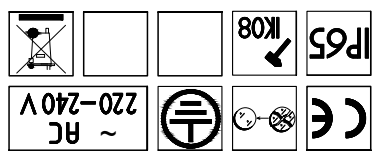
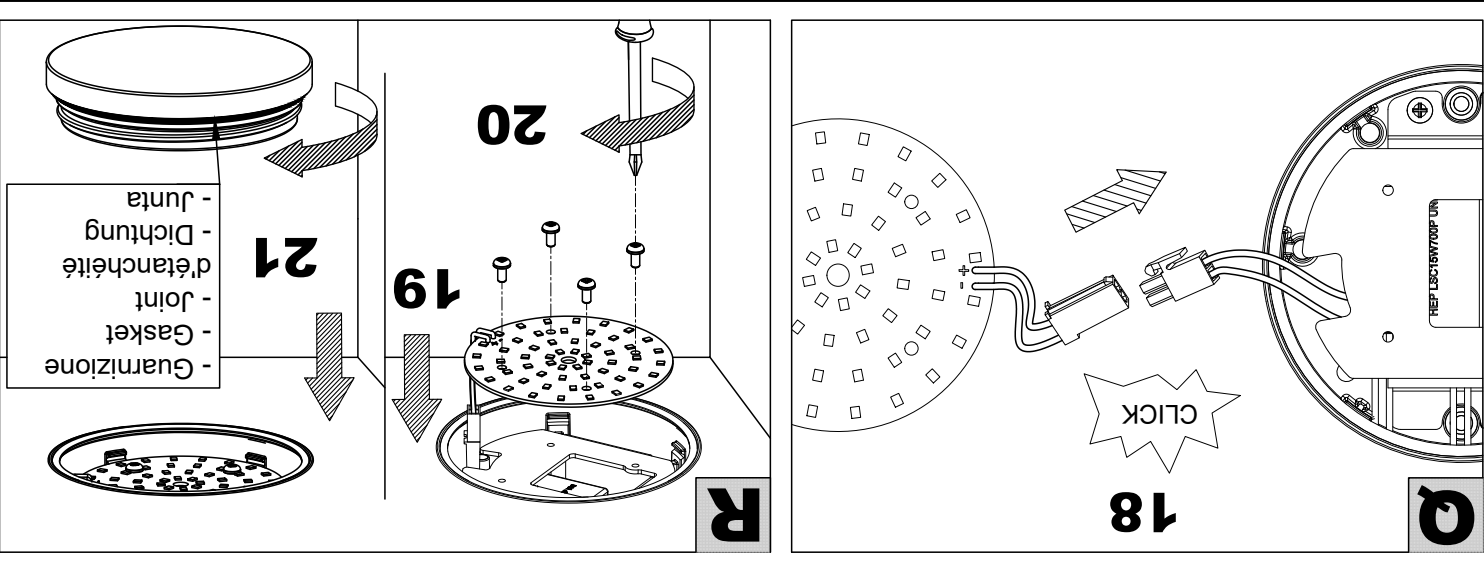
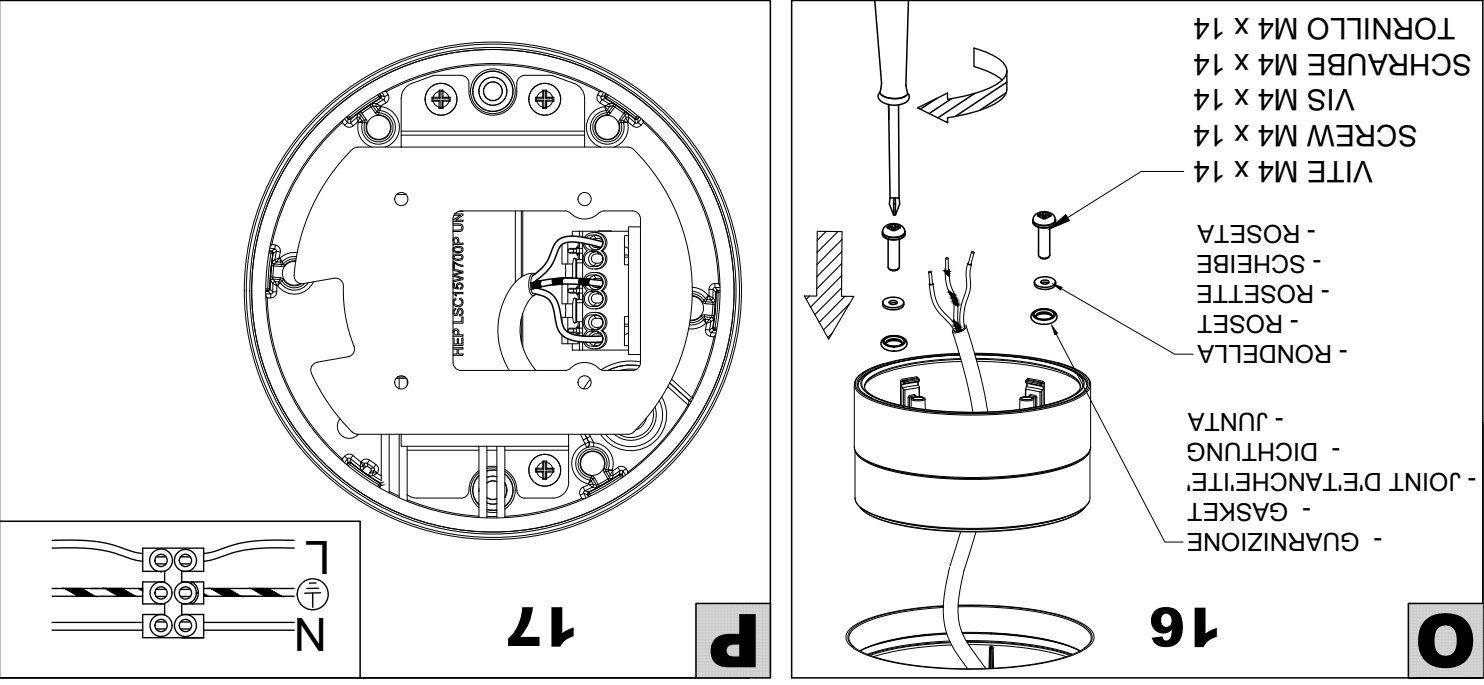
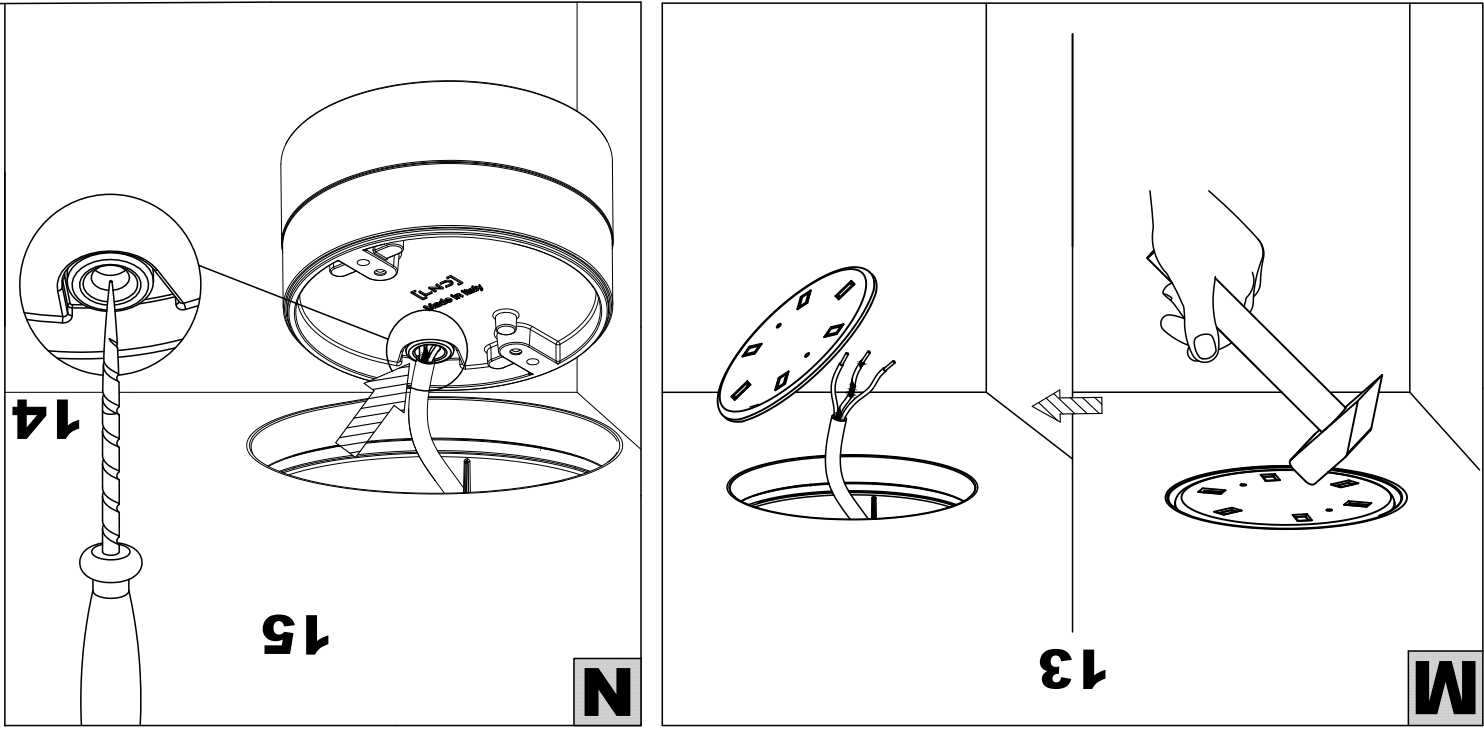

[LNJ] FG60ISODXB10X

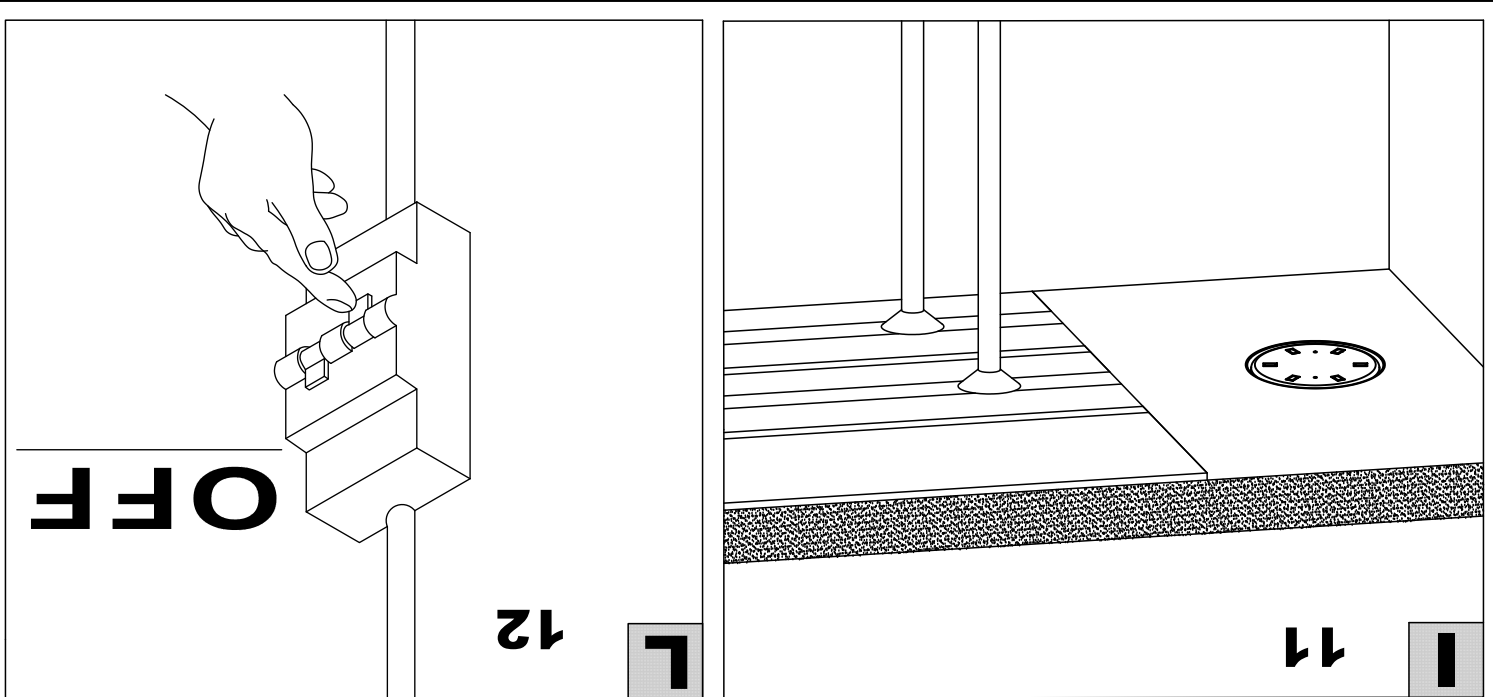
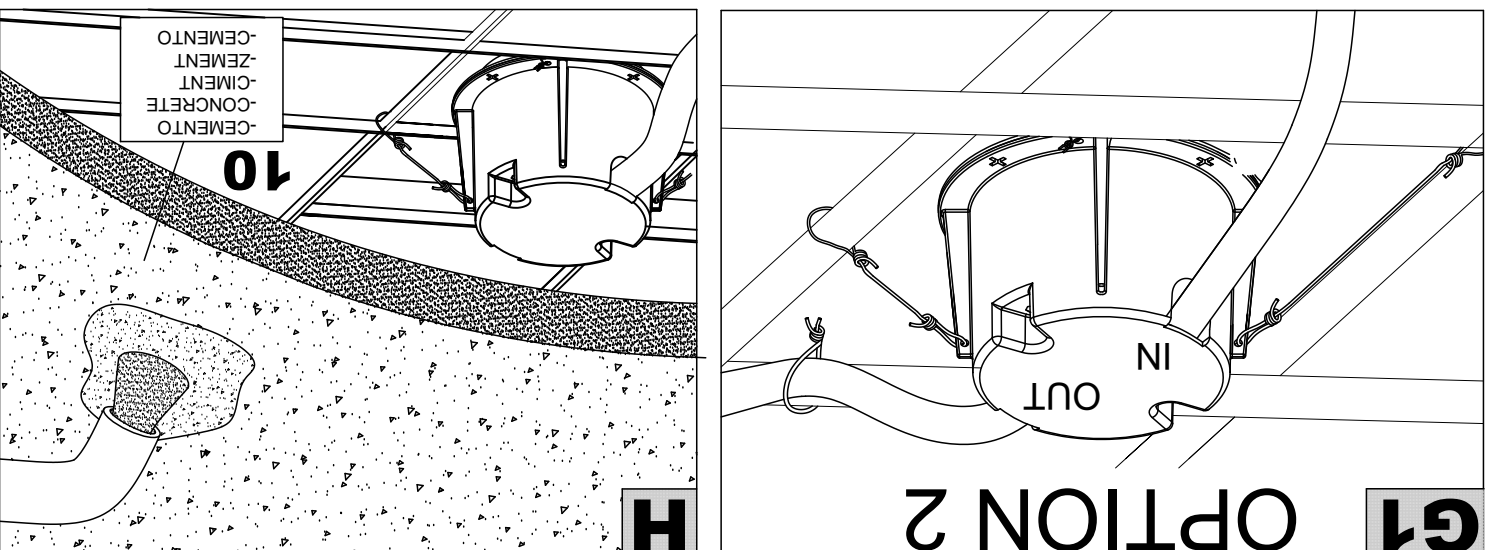
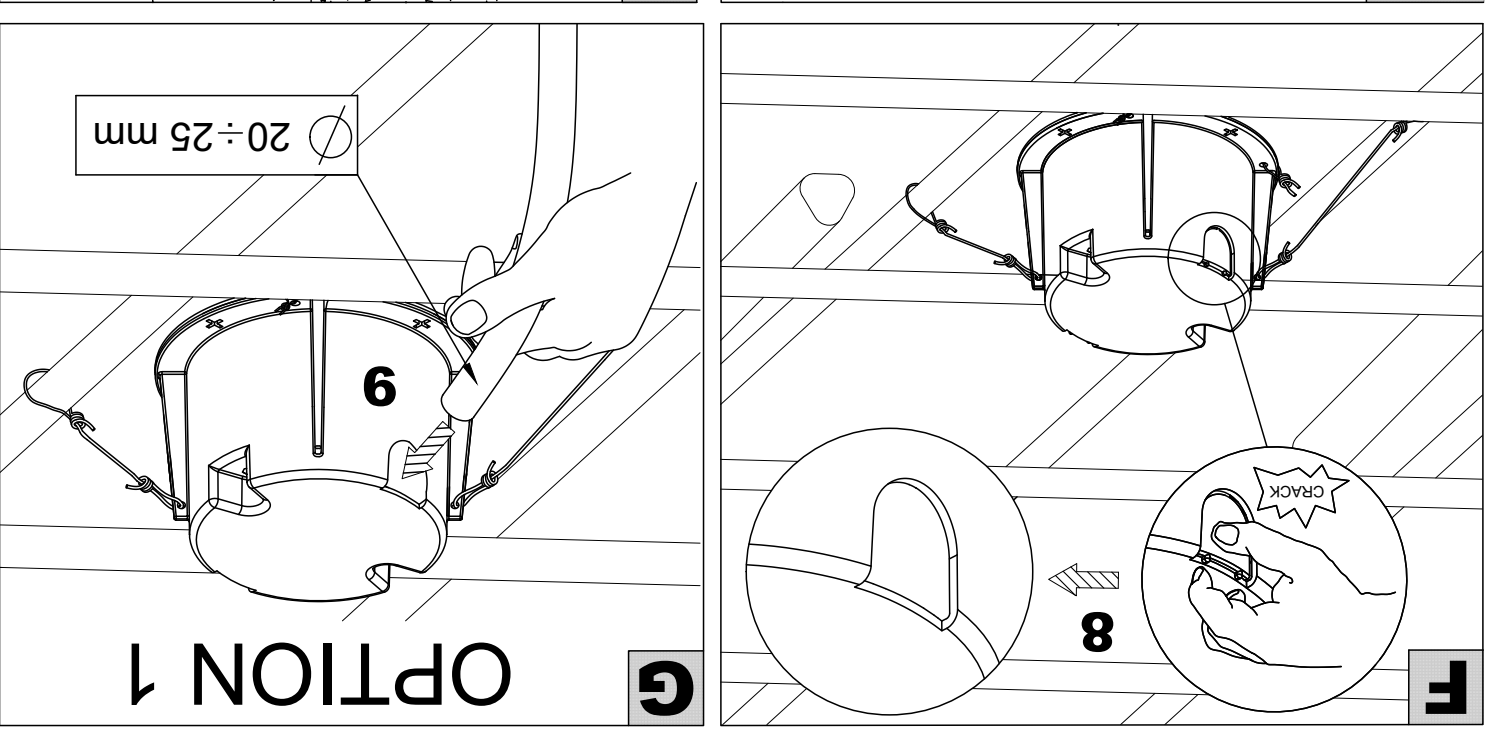

20: - Junta
21: - Dichtung
 détancheite
 - Joint
 - Gasket
 - Guarnizione

16: - GUARNIZIONE
 - GASKET
 - JOINT DETANCHEITE
 - DICHTUNG
 - JUNTA
 - RONDELLA
 - ROSET
 - ROSETTE
 - SCHEIBE
 - ROSETTA
 VITE M4 x 14
 SCHRAUBE M4 x 14
 VIS M4 x 14
 TORNILLO M4 x 14

10: -CEMENTO
 -CONCRETE
 -CEMENT

OFF