



**BETRIEBSANLEITUNG FÜR
DECKENAUFBAULEUCHTE**
Diamond II / Crono II Sensor

**MODE D'EMPLOI POUR
PLAFONNIER**
Diamond II / Crono II Capteur

**ISTRUZIONI DI FUNZIONAMENTO PER
APPARECCHIO A PLAFONE**
Diamond II / Crono II Sensore

**OPERATING MANUAL FOR
CEILING MOUNTED LUMINAIRE**
Diamond II / Crono II Sensor

160-242-70 / Diamond Ø 300mm
160-247-70 / Diamond Ø 400mm

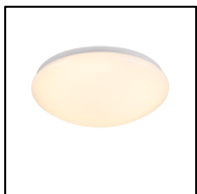

160-252-70 / Crono Ø 300mm
160-257-70 / Crono Ø 400mm

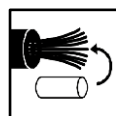
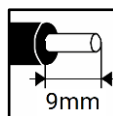
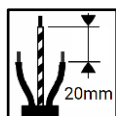
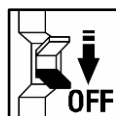
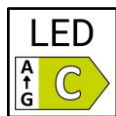
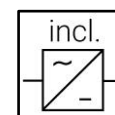
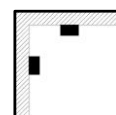
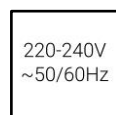
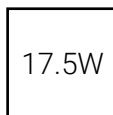
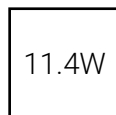
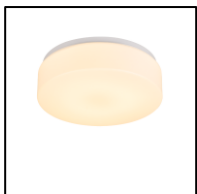

DE Die Montage und Inbetriebnahme darf nur von autorisiertem Fachpersonal durchgeführt werden (Elektroinstallateur). Die Leuchte dient ausschliesslich der Beleuchtung und ist entsprechend den Errichtungsbestimmungen zu installieren. Eine andere Nutzung oder ein anderer Einbau gilt als nicht „bestimmungsgemäss“.

Achtung! Während der Verdrahtung und Installation der Leuchten und Versorgungsgeräte immer spannungslos arbeiten. Nichtbeachten kann zur Zerstörung der LED-Module führen. **Bei Defekt zurück an Hersteller.** Die Montageanleitung muss aufbewahrt werden. Technische Änderungen vorbehalten.

FR Le montage et la mise en service ne peuvent être effectués que par du personnel spécialisé autorisé (installateur électrique). Le luminaire sert uniquement à éclairer et doit être installé conformément aux dispositions d'édification. Une autre utilisation ou intégration est considérée comme «non conforme aux dispositions».

Attention! Toujours travailler hors tension lors du câblage et de l'installation des luminaires et unités d'alimentation. Le non-respect de cette consigne peut entraîner la destruction des modules à LED. **Retourner au fabricant en cas de défaut.** L'instruction de montage doit être conservée. Sous réserve de modifications.

IT Montaggio e messa in funzione possono essere effettuati solo da personale specializzato autorizzato (elettoinstallatori). Il proiettore serve esclusivamente a scopo di illuminazione e deve essere installato secondo le disposizioni di montaggio. Un altro utilizzo o un'altra modalità di incasso sono considerati "non conformi".

Attenzione! Lavorare sempre in assenza di tensione mentre si cablano e si installano gli apparecchi e le unità di alimentazione. In caso contrario i moduli LED possono andare distrutti! **In caso di guasto rispedire il proiettore al produttore.** Le istruzioni di montaggio devono essere conservate. I dati tecnici possono subire modifiche senza preavviso.

EN Installation and commissioning may only be carried out by authorised technical personnel (electricians). The luminaire is designed solely for lighting and is to be installed according to the installation instructions. Any other use or any other installation is considered to be improper.

Caution! Make sure that the luminaires and power supply units are always disconnected from the main supply during wiring and installation work. Otherwise, the LED modules may be destroyed. **Return to manufacturer if defects are found.** The Operating manual must be kept. Subject to technical change without notice.

Technische Änderungen vorbehalten / Les détails techniques sont sujet à des changements.
Modifiche tecniche riservate / Technical Details are subject to change.
Seite 1/4, 14.08.2024 © unex lighting AG, Flüelastrasse 12, 8048 Zürich

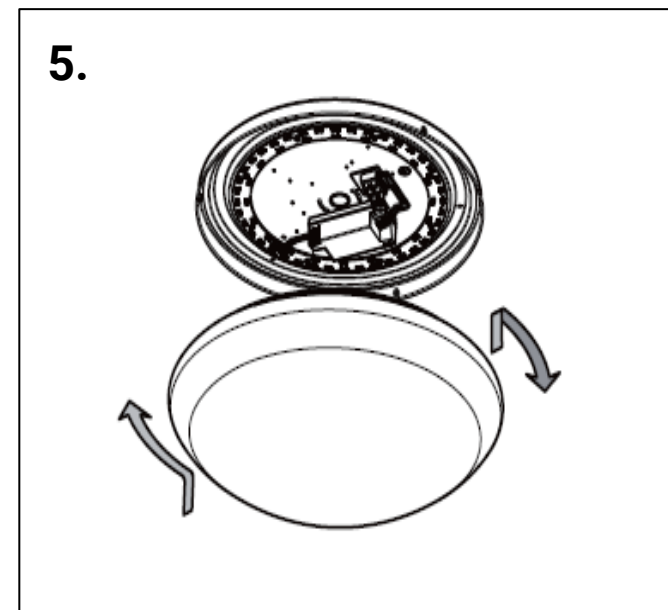
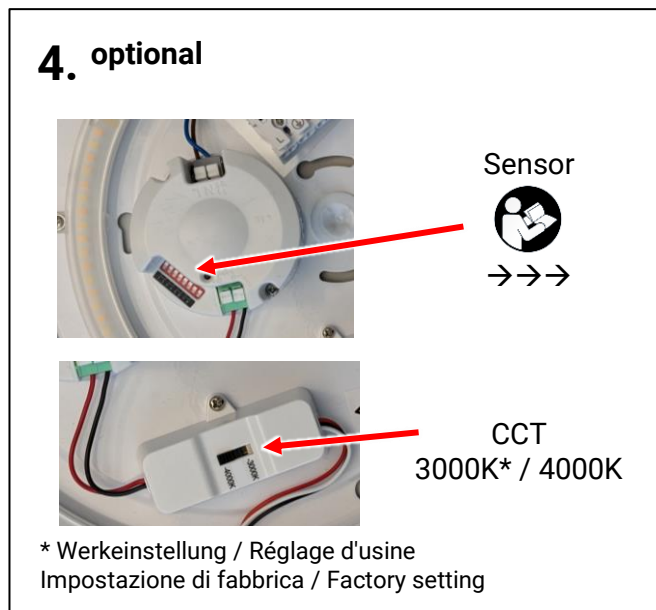
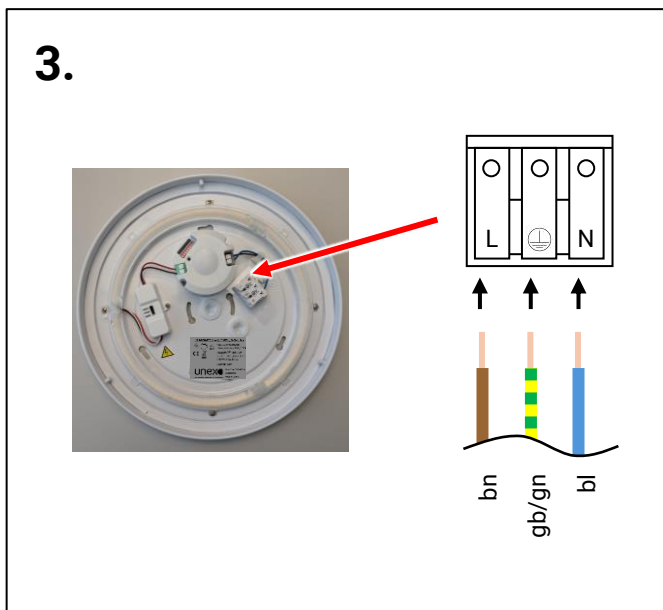
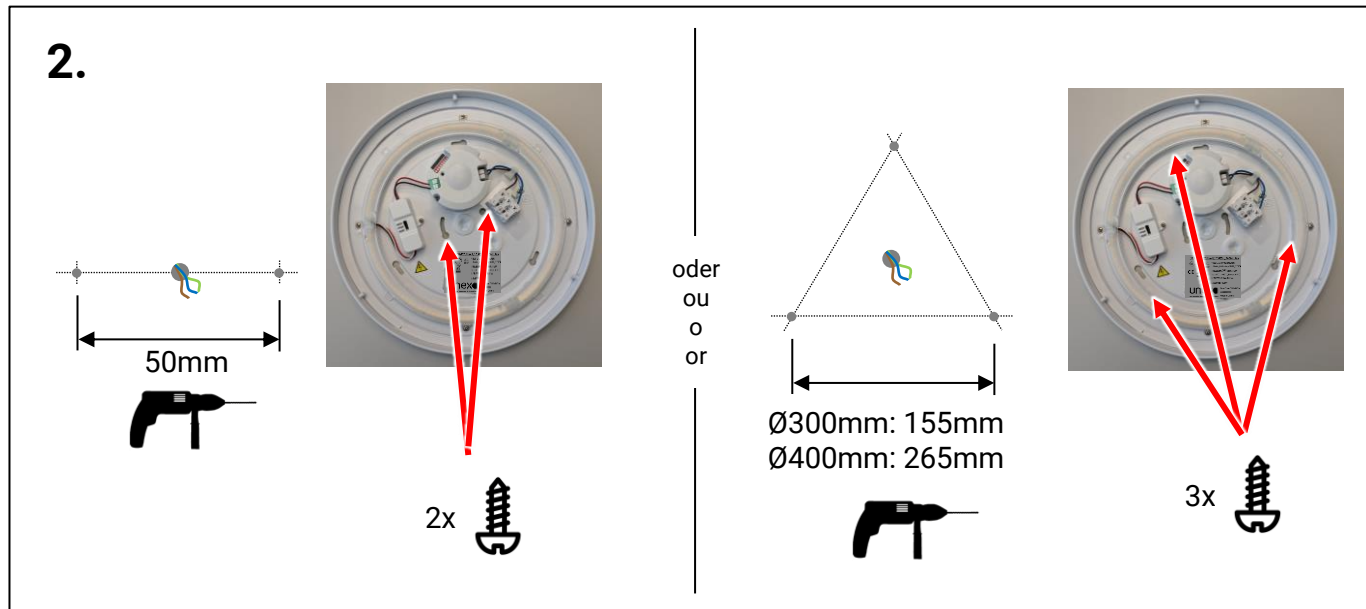
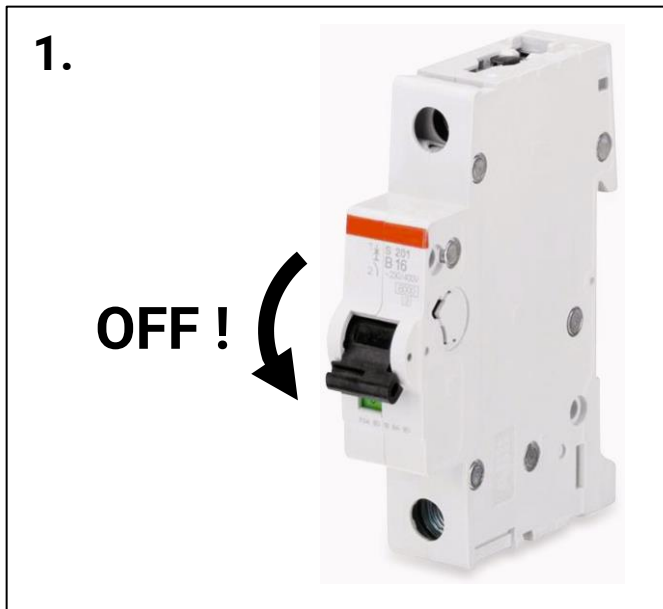

DE DIP-Schalter Positionen * Werkeinstellung ** Funktion deaktiviert	FR Position d'interrupteur DIP * Réglage d'usine ** Fonction déactivé	IT Posizioni di Interruttore DIP * Impostazione di fabbrica ** Funzione disattivata	EN DIP-Switch positions * Factory setting ** Function disabled																										
Erkennungsbereich	Zone de détection	Area di rilevazione	Detection Area	<table border="1"> <thead> <tr> <th>1</th> <th>2</th> <th></th> <th></th> </tr> </thead> <tbody> <tr> <td>ON</td> <td>ON</td> <td>100%</td> <td>*</td> </tr> <tr> <td>-</td> <td>ON</td> <td>75%</td> <td></td> </tr> <tr> <td>ON</td> <td>-</td> <td>50%</td> <td></td> </tr> <tr> <td>-</td> <td>-</td> <td>25%</td> <td></td> </tr> </tbody> </table>	1	2			ON	ON	100%	*	-	ON	75%		ON	-	50%		-	-	25%						
1	2																												
ON	ON	100%	*																										
-	ON	75%																											
ON	-	50%																											
-	-	25%																											
Haltezeit	Temps de maintien	Tempo di mantenimento	Hold Time	<table border="1"> <thead> <tr> <th>3</th> <th>4</th> <th></th> <th></th> </tr> </thead> <tbody> <tr> <td>ON</td> <td>ON</td> <td>5s</td> <td>*</td> </tr> <tr> <td>-</td> <td>ON</td> <td>90s</td> <td></td> </tr> <tr> <td>ON</td> <td>-</td> <td>3min</td> <td></td> </tr> <tr> <td>-</td> <td>-</td> <td>10min</td> <td></td> </tr> </tbody> </table>	3	4			ON	ON	5s	*	-	ON	90s		ON	-	3min		-	-	10min						
3	4																												
ON	ON	5s	*																										
-	ON	90s																											
ON	-	3min																											
-	-	10min																											
Tageslichtsensor	Capteur de lumière du jour	Sensore di luce diurna	Daylight Sensor	<table border="1"> <thead> <tr> <th>5</th> <th>6</th> <th>→ ON</th> <th>→ OFF</th> <th></th> </tr> </thead> <tbody> <tr> <td>ON</td> <td>ON</td> <td colspan="2">Disabled **</td> <td>*</td> </tr> <tr> <td>-</td> <td>ON</td> <td>< 50lux</td> <td>> 150lux</td> <td></td> </tr> <tr> <td>ON</td> <td>-</td> <td>< 15lux</td> <td>> 100lux</td> <td></td> </tr> <tr> <td>-</td> <td>-</td> <td>< 5lux</td> <td>> 50lux</td> <td></td> </tr> </tbody> </table>	5	6	→ ON	→ OFF		ON	ON	Disabled **		*	-	ON	< 50lux	> 150lux		ON	-	< 15lux	> 100lux		-	-	< 5lux	> 50lux	
5	6	→ ON	→ OFF																										
ON	ON	Disabled **		*																									
-	ON	< 50lux	> 150lux																										
ON	-	< 15lux	> 100lux																										
-	-	< 5lux	> 50lux																										
Stand-by-Zeit	temps de veille	tempo di stand-by	Stand-by period	<table border="1"> <thead> <tr> <th>7</th> <th>8</th> <th></th> <th></th> </tr> </thead> <tbody> <tr> <td>ON</td> <td>ON</td> <td>0s **</td> <td>*</td> </tr> <tr> <td>-</td> <td>ON</td> <td>30s</td> <td></td> </tr> <tr> <td>ON</td> <td>-</td> <td>10min</td> <td></td> </tr> <tr> <td>-</td> <td>-</td> <td>∞</td> <td></td> </tr> </tbody> </table>	7	8			ON	ON	0s **	*	-	ON	30s		ON	-	10min		-	-	∞						
7	8																												
ON	ON	0s **	*																										
-	ON	30s																											
ON	-	10min																											
-	-	∞																											

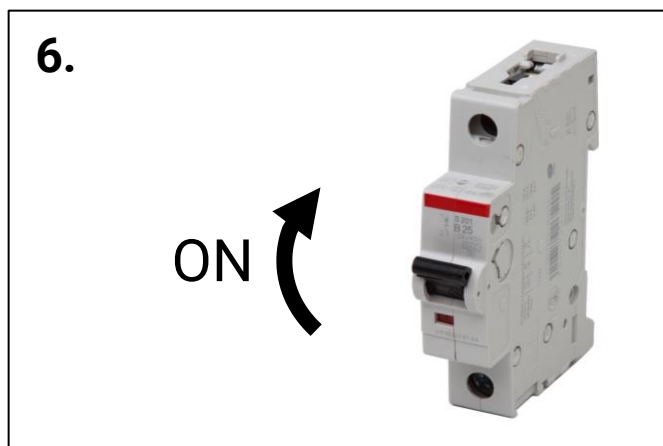

7.

DE Initialisierung
FR Initialisation
IT Inizializzazione
EN Initialisation

10s

DE

Reinigung und Pflege

Reinigung nur mit trockenem oder feuchtem Mikrofasertuch.

Lichtquelle ersetzen

Die Lichtquelle ist nur durch eine Fachkraft austauschbar.

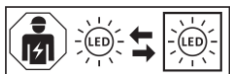

Netzteil ersetzen

Das Betriebsgerät ist nur durch eine Fachkraft austauschbar.

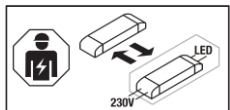

Effizienzklasse

Dieses Produkt enthält eine Lichtquelle der Energieeffizienzklasse C.



FR

Nettoyage et entretien

Nettoyage seulement avec chiffon microfibre sec ou humide.

Remplacer la source lumineuse

La source lumineuse peut uniquement être remplacée par un spécialiste.

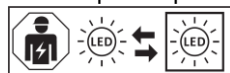

Remplacer le bloc d'alimentation

L'auxiliaire de commande peut uniquement être remplacé par un spécialiste.

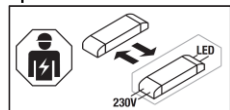

Efficacité énergétique

Ce produit contient une source lumineuse de la classe d'efficacité énergétique C.



IT

Cura e pulizia

Pulire solo con un panno in microfibra asciutto o umido.

Sostituire la sorgente luminosa

La sorgente luminosa può essere sostituita solo da personale autorizzato.

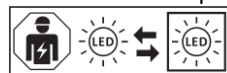

Sostituire l'alimentatore

Il dispositivo di alimentazione può essere sostituito solo da personale autorizzato.

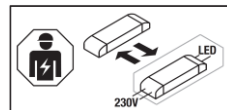

Efficienza energetica

Questo prodotto contiene una sorgente luminosa con classe di efficienza energetica C.



EN

Cleaning and care

Only use dry or moist microfiber cloth for cleaning.

Replacement of light source

The light source is only replaceable by a professional.

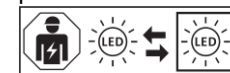

Replacement of power supply

The separate control unit is only replaceable by a professional.

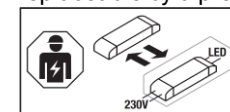

Energy efficiency

This product contains a light source of the energy efficiency class C.

